

KOŁA ZĘBATE METRYCZNE O PODZIAŁCE "M" POD PASY HTD

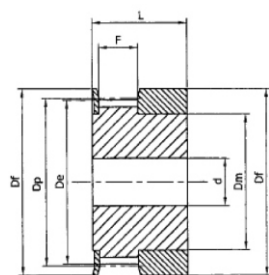

TYP 1F

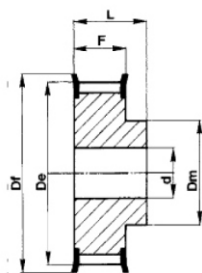

TYP 6F

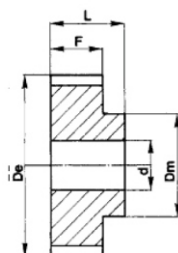

TYP 6



HTD 3M-06 dla pasa zębatego o szerokości 6 mm

INFORMACJE DODATKOWE	RODZAJ	TYP	LICZBA ZĘBÓW	Dp	De	Df	Dm	F	L	d	WAGA KG	
ALUMINIUM 6082 T6 UNI 9006/4	Z FLANSZĄ	10-3M-06	1F	10	9,55	8,79	13	6	7,2	14,5	4	-
		12-3M-06	1F	12	11,46	10,70	15	8	7,2	14,5	4	-
		14-3M-06	1F	14	13,37	12,61	16	9,5	7,2	14,5	4	-
		15-3M-06	1F	15	14,32	13,56	17,5	11,6	7,2	14,5	4	-
		16-3M-06	6F	16	15,28	14,52	18	10	9,8	17,5	4	-
		18-3M-06	6F	18	17,19	16,43	20	11	9,8	17,5	6	-
		20-3M-06	6F	20	19,10	18,34	23	13	9,8	17,5	6	-
		21-3M-06	6F	21	20,05	19,29	25	13	9,8	17,5	6	-
		22-3M-06	6F	22	21,01	20,25	25	13	9,8	17,5	6	-
		24-3M-06	6F	24	22,92	22,16	25	13	9,8	17,5	6	-
	26-3M-06	6F	26	24,83	24,07	28	16	9,8	17,5	6	-	
	28-3M-06	6F	28	26,74	25,08	32	18	9,8	17,5	6	-	
	30-3M-06	6F	30	28,65	27,89	32	20	9,8	17,5	6	-	
	32-3M-06	6F	32	30,56	29,80	36	22	9,8	17,5	6	-	
	36-3M-06	6F	36	34,38	33,62	38	26	10,3	18	6	-	
	40-3M-06	6F	40	38,20	37,44	42	28	10,3	18	6	-	
	44-3M-06	6F	44	42,02	41,26	48	33	10,3	18	6	-	
	BEZ FLANSZY	48-3M-06	6	48	45,84	45,08	-	33	10,3	18,6	8	-
		60-3M-06	6	62	57,30	56,54	-	33	10,3	18,6	8	-
		72-3M-06	6	72	68,75	67,99	-	33	10,3	18,6	8	-

KOŁA ZĘBATE METRYCZNE O PODZIAŁCE "M" POD PASY HTD

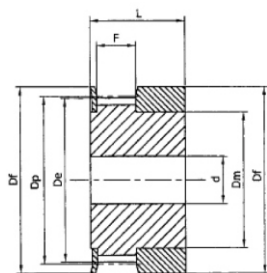

TYP 1F

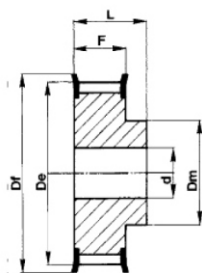

TYP 6F

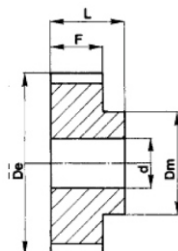

TYP 6



HTD 3M-09 dla pasa zębatego o szerokości 9 mm

INFORMACJE DODATKOWE	RODZAJ	TYP	ILOŚĆ ZĘBÓW	Dp	De	Df	Dm	F	L	d	WAGA KG	
ALUMINIUM 6082 T6 UNI 9006/4	Z FLANSZĄ	10-3M-09	1F	10	9,55	8,79	13	6	10,2	17,5	4	0,004
		12-3M-09	1F	12	11,46	10,70	15	8	10,2	17,5	4	0,006
		14-3M-09	1F	14	13,37	12,61	16	9,5	10,2	17,5	4	0,007
		15-3M-09	1F	15	14,32	13,56	17,5	11,6	10,2	17,5	4	0,008
		16-3M-09	6F	16	15,28	14,52	18	10	12,8	20,6	4	0,007
		18-3M-09	6F	18	17,19	16,43	20	11	12,8	20,6	6	0,008
		20-3M-09	6F	20	19,10	18,34	23	13	12,8	20,6	6	0,010
		21-3M-09	6F	21	20,05	19,29	25	13	12,8	20,6	6	0,013
		22-3M-09	6F	22	21,01	20,25	25	13	12,8	20,6	6	0,014
		24-3M-09	6F	24	22,92	22,16	25	13	12,8	20,6	6	0,016
	26-3M-09	6F	26	24,83	24,07	28	16	12,8	20,6	6	0,018	
	28-3M-09	6F	28	26,74	25,98	32	18	12,8	20,6	6	0,024	
	30-3M-09	6F	30	28,65	27,89	32	20	12,8	20,6	6	0,028	
	32-3M-09	6F	32	30,56	29,80	36	22	12,8	20,6	6	0,032	
	36-3M-09	6F	36	34,38	33,62	38	26	13,4	22,2	6	0,045	
	40-3M-09	6F	40	38,20	37,44	42	28	13,4	22,2	6	0,055	
	44-3M-09	6F	44	42,02	41,26	48	33	13,4	22,2	6	0,074	
	BEZ FLANSZY	48-3M-09	6	48	45,84	45,08	-	33	13,4	22,2	8	0,074
		60-3M-09	6	60	57,30	56,54	-	33	13,4	22,2	8	0,106
		72-3M-09	6	72	68,75	67,99	-	33	13,4	22,2	8	0,145

HTD 3M-15 dla pasa zębatego o szerokości 15 mm

INFORMACJE DODATKOWE	RODZAJ	TYP	ILOŚĆ ZĘBÓW	Dp	De	Df	Dm	F	L	d	WAGA KG	
ALUMINIUM 6082 T6 UNI 9006/4	Z FLANSZĄ	10-3M-15	1f	10	9,55	8,79	13	6	17	26	4	0,006
		12-3M-15	1f	12	11,46	10,70	15	8	17	26	4	0,008
		14-3M-15	1f	14	13,37	12,61	16	9,5	17	26	4	0,010
		15-3M-15	1f	15	14,32	13,56	17,5	11,6	17	26	4	0,012
		16-3M-15	6f	16	15,28	14,52	18	10	19,5	26	4	0,010
		18-3M-15	6f	18	17,19	16,43	20	11	19,5	26	6	0,012
		20-3M-15	6f	20	19,10	18,34	23	12	19,5	26	6	0,014
		21-3M-15	6f	21	20,05	19,29	25	13	19,5	26	6	0,016
		22-3M-15	6f	22	21,01	20,25	25	13	19,5	26	6	0,018
		24-3M-15	6f	24	22,92	22,16	25	13	19,5	26	6	0,020
	26-3M-15	6F	26	24,83	24,07	28	16	19,5	26	6	0,027	
	28-3M-15	6F	28	26,74	25,98	32	18	19,5	26	6	0,030	
	30-3M-15	6F	30	28,65	27,89	32	20	19,5	26	6	0,035	
	32-3M-15	6F	32	30,56	29,80	36	22	19,5	26	6	0,042	
	36-3M-15	6F	36	34,38	33,62	38	26	20	30	6	0,060	
	40-3M-15	6F	40	38,20	37,44	42	28	20	30	6	0,075	
	44-3M-15	6F	44	42,02	41,26	48	33	20	30	6	0,095	
	BEZ FLANSZY	48-3M-15	6	48	45,84	45,08	-	33	20	30	8	0,103
		60-3M-15	6	60	57,30	56,54	-	33	20	30	8	0,150
		72-3M-15	6	72	68,75	67,99	-	33	20	30	8	0,212

KOŁA ZĘBATE METRYCZNE O PODZIAŁCE "M" POD PASY HTD

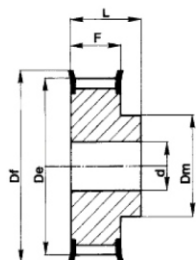

TYP 6F

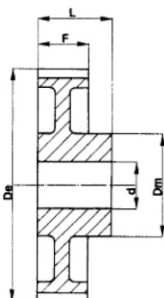

TYP 6W



HTD 5M-09 dla pasa zębatego o szerokości 9 mm

INFORMACJE DODATKOWE	RODZAJ	TYP	LICZBA ZĘBÓW	Dp	De	Df	Dm	Di	F	L	d	WAGA KG	
STAL	Z FLANSZĄ	12-5M-09	6F	12	19,10	17,96	23	12	-	14,5	20	4	0,028
		14-5M-09	6F	14	22,28	21,14	25	13	-	14,5	20	6	0,034
		15-5M-09	6F	15	23,87	22,73	28	16	-	14,5	20	6	0,042
		16-5M-09	6F	16	25,46	24,32	28	16,5	-	14,5	20	6	0,050
		18-5M-09	6F	18	28,65	27,51	32	20	-	14,5	20	6	0,070
		20-5M-09	6F	20	31,83	30,69	36	23	-	14,5	22,5	6	0,094
		21-5M-09	6F	21	33,42	32,28	38	24	-	14,5	22,5	6	0,110
		22-5M-09	6F	22	35,01	33,87	38	25,5	-	14,5	22,5	6	0,118
		24-5M-09	6F	24	38,20	37,06	42	27	-	14,5	22,5	6	0,145
		26-5M-09	6F	26	41,38	40,24	44	30	-	14,5	22,5	6	0,170
		28-5M-09	6F	28	44,56	43,42	48	30,5	-	14,5	22,5	6	0,200
		30-5M-09	6F	30	47,75	46,60	51	35	-	14,5	22,5	6	0,236
		32-5M-09	6F	32	50,93	49,79	54	38	-	14,5	22,5	8	0,210
		36-5M-09	6F	36	57,30	56,16	60	38	-	14,5	22,5	8	0,324
40-5M-09	6F	40	63,66	62,52	70	38	-	14,5	22,5	8	0,400		
ALUMINIUM	BEZ FLANSZY	44-5M-09	6W	44	70,03	68,89	-	38	54	14,5	25,5	8	0,170
		48-5M-09	6W	48	76,39	75,25	-	45	61	14,5	25,5	8	0,182
		60-5M-09	6W	60	95,46	94,35	-	45	80	14,5	25,5	8	0,230
		72-5M-09	6W	72	114,59	113,45	-	45	100	14,5	25,5	8	0,270

KOŁA ZĘBATE METRYCZNE O PODZIAŁCE "M" POD PASY HTD

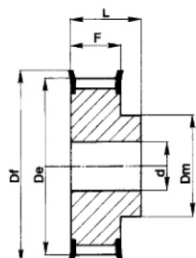

TYP 6F

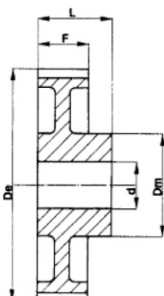

TYP 6W



HTD 5M-15 dla pasa zębatego o szerokości 15 mm

INFORMACJE DODATKOWE		RODZAJ	TYP	ILOŚĆ ZĘBÓW	Dp	De	Df	Dm	Di	F	L	d	WAGA KG
STAL	Z FLANSZĄ	12-5M-15	6F	12	19,10	17,96	23	12	-	20,5	26	4	0,034
		14-5M-15	6F	14	22,28	21,14	25	13	-	20,5	26	6	0,046
		15-5M-15	6F	15	23,87	22,73	28	16	-	20,5	26	6	0,056
		16-5M-15	6F	16	25,46	24,32	28	16,5	-	20,5	26	6	0,064
		18-5M-15	6F	18	28,65	27,51	32	20	-	20,5	26	6	0,086
		20-5M-15	6F	20	31,83	30,69	36	23	-	20,5	26	6	0,112
		21-5M-15	6F	21	33,42	32,28	38	24	-	20,5	26	6	0,130
		22-5M-15	6F	22	35,01	33,87	38	25,5	-	20,5	26	6	0,140
		24-5M-15	6F	24	38,20	37,06	42	27	-	20,5	28	6	0,180
		26-5M-15	6F	26	41,38	40,24	44	30	-	20,5	28	6	0,220
		28-5M-15	6F	28	44,56	43,42	48	30,5	-	20,5	28	6	0,250
		30-5M-15	6F	30	47,75	46,60	51	35	-	20,5	28	6	0,300
		32-5M-15	6F	32	50,93	49,79	54	38	-	20,5	28	6	0,350
36-5M-15	6F	36	57,30	56,16	60	38	-	20,5	28	6	0,426		
40-5M-15	6F	40	63,66	62,52	70	38	-	20,5	28	6	0,520		
ALUMINIUM	BEZ FLANSZY	44-5M-15	6W	44	70,03	68,89	-	38	54	20,5	30	8	0,225
		48-5M-15	6W	48	76,39	75,25	-	45	61	20,5	30	8	0,187
		60-5M-15	6W	60	95,46	94,35	-	45	80	20,5	30	8	0,305
		72-5M-15	6W	72	114,59	113,45	-	45	100	20,5	30	8	0,305

HTD 5M-25 dla pasa zębatego o szerokości 25 mm

INFORMACJE DODATKOWE		RODZAJ	TYP	ILOŚĆ ZĘBÓW	Dp	De	Df	Dm	Di	F	L	d	WAGA KG
STAL	Z FLANSZĄ	12-5M-25	6F	12	19,10	17,96	23	12	-	30,5	36	4	0,050
		14-5M-25	6F	14	22,28	21,14	25	13	-	30,5	36	6	0,070
		15-5M-25	6F	15	23,87	22,73	28	16	-	30,5	36	6	0,080
		16-5M-25	6F	16	25,46	24,32	28	16,5	-	30,5	36	6	0,100
		18-5M-25	6F	18	28,65	27,51	32	20	-	30,5	36	6	0,120
		20-5M-25	6F	20	31,83	30,69	36	23	-	30,5	36	6	0,160
		21-5M-25	6F	21	33,42	32,28	38	24	-	30,5	38	6	0,190
		22-5M-25	6F	22	35,01	33,87	38	25,5	-	30,5	38	6	0,210
		24-5M-25	6F	24	38,20	37,06	42	27	-	30,5	38	6	0,250
		26-5M-25	6F	26	41,38	40,24	44	30	-	30,5	38	6	0,300
		28-5M-25	6F	28	44,56	43,42	48	30,5	-	30,5	38	6	0,350
		30-5M-25	6F	30	47,75	46,60	51	35	-	30,5	38	6	0,420
		32-5M-25	6F	32	50,93	49,79	54	38	-	30,5	38	8	0,480
36-5M-25	6F	36	57,30	56,16	60	38	-	30,5	38	8	0,590		
40-5M-25	6F	40	63,66	62,52	70	38	-	30,5	38	8	0,740		
ALUMINIUM	BEZ FLANSZY	44-5M-25	6W	44	70,03	68,89	-	38	54	30,5	40	8	0,320
		48-5M-25	6W	48	76,39	75,25	-	45	61	30,5	40	8	0,275
		60-5M-25	6W	60	95,46	94,35	-	45	80	30,5	40	8	0,435
		72-5M-25	6W	72	114,59	113,45	-	45	100	30,5	40	8	0,525

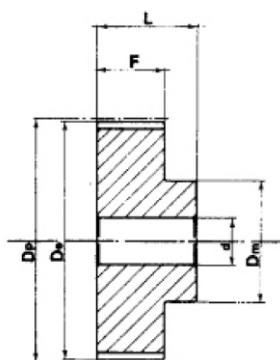

TYP 6

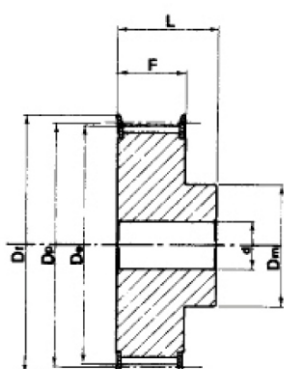

TYP 6F

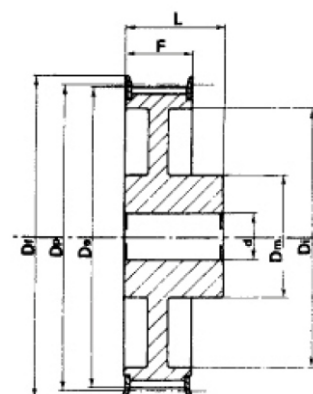

TYP 6WF

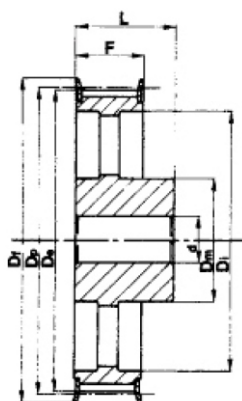

TYP 6AF

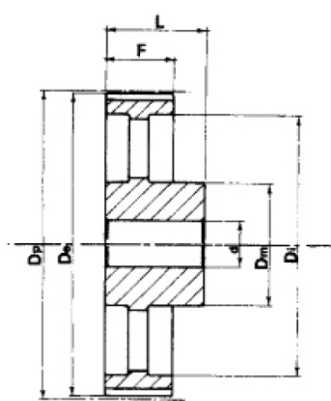

TYP 6A

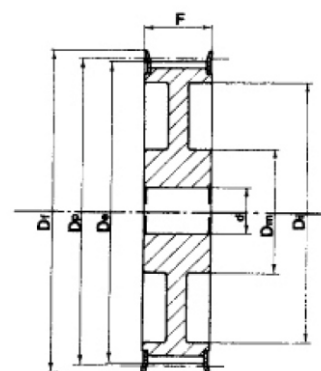

TYP 10WF

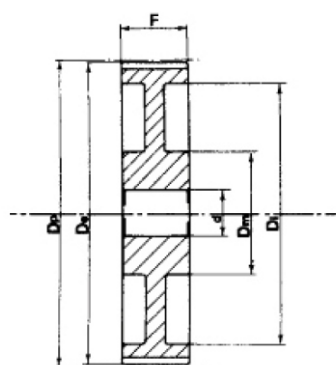

TYP 10W

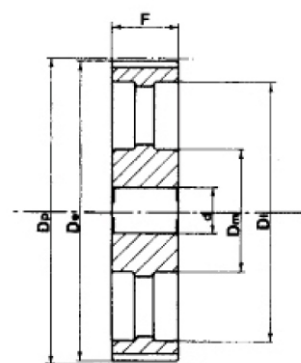

TYP 10W

KOŁA ZĘBATE METRYCZNE O PODZIAŁCE "M" POD PASY HTD

HTD 8M-20 dla pasa zębatego o szerokości 20 mm

INFORMACJE DODATKOWE	RODZAJ	TYP	ILOŚĆ ZĘBÓW	Dp	De	Df	Dm	Di	F	L	d	WAGA KG	
STAL	Z FLANSZĄ	22-8M-20	6F	22	50,02	54,65	60	43	-	28	38	12	0,54
		24-8M-20	6F	24	61,12	59,75	66	45	-	28	38	12	0,65
		26-8M-20	6F	26	66,21	64,84	70	48	-	28	38	12	0,80
		28-8M-20	6F	28	71,30	70,08	75	50	-	28	38	15	0,87
		30-8M-20	6F	30	76,39	75,13	83	55	-	28	38	15	1,02
		32-8M-20	6F	32	81,49	80,16	87	60	-	28	38	15	1,20
		34-8M-20	6F	34	86,58	85,22	91	70	-	28	38	15	1,40
		36-8M-20	6F	36	91,67	90,30	97	75	-	28	38	15	1,55
		38-8M-20	6F	38	96,77	95,39	102	75	-	28	38	15	1,65
		40-8M-20	6F	40	101,96	100,49	106	75	-	28	38	15	1,74
		44-8M-20	6F	44	112,05	110,67	120	75	-	28	38	15	2,10
		48-8M-20	6F	48	122,23	120,86	128	75	-	28	38	15	2,44
		56-8M-20	6WF	56	142,60	141,23	150	80	116	28	38	15	2,60
		64-8M-20	6WF	64	162,97	161,60	168	80	137	28	38	15	2,90
		72-8M-20	6WF	72	183,35	181,97	192	80	158	28	38	15	3,10
ŻELIWO	BEZ FLANSZY	80-8M-20	6W	80	203,72	202,35	-	90	180	28	38	15	3,80
		90-8M-20	6A	90	229,18	227,81	-	90	204	28	38	15	4,20
		112-8M-20	6A	112	285,21	283,83	-	90	254	28	38	18	5,20
		144-8M-20	6A	144	366,69	365,32	-	90	336	28	38	20	7,50
		168-8M-20	6A	168	427,81	426,44	-	100	400	28	38	20	10,00
192-8M-20	6A	192	488,92	487,55	-	100	460	28	38	20	14,40		

HTD 8M-30 dla pasa zębatego o szerokości 30 mm

INFORMACJE DODATKOWE	RODZAJ	TYP	ILOŚĆ ZĘBÓW	Dp	De	Df	Dm	Di	F	L	d	WAGA KG	
STAL	Z FLANSZĄ	22-8M-30	6F	22	56,02	54,65	60	43	-	38	48	12	0,69
		24-8M-30	6F	24	61,12	59,75	66	45	-	38	48	12	0,84
		26-8M-30	6F	26	66,21	64,84	70	48	-	38	48	12	1,00
		28-8M-30	6F	28	71,30	70,08	75	50	-	38	48	15	1,12
		30-8M-30	6F	30	76,39	75,13	83	55	-	38	48	15	1,32
		32-8M-30	6F	32	81,49	80,16	87	60	-	38	48	15	1,53
		34-8M-30	6F	34	86,58	85,22	91	70	-	38	48	15	1,80
		36-8M-30	6F	36	91,67	90,30	97	75	-	38	48	15	1,99
		38-8M-30	6F	38	96,77	95,39	102	75	-	38	48	15	2,27
		40-8M-30	6F	40	101,86	100,49	106	75	-	38	48	15	2,40
		44-8M-30	6F	44	112,05	110,67	120	75	-	38	48	15	2,80
		48-8M-30	6F	48	122,23	120,66	128	75	-	38	48	15	3,20
		56-8M-30	6WF	56	142,60	141,23	150	90	116	38	48	15	3,60
		64-8M-30	6WF	64	162,97	161,60	168	90	137	38	48	15	4,30
		72-8M-30	6WF	72	183,35	181,97	192	95	158	38	48	15	4,80
ŻELIWO	BEZ FLANSZY	80-8M-30	6W	80	203,72	202,35	-	100	180	38	48	15	5,10
		90-8M-30	6A	90	229,18	227,81	-	100	204	38	48	15	5,70
		112-8M-30	6A	112	285,21	283,83	-	100	254	38	48	18	6,80
		144-8M-30	6A	144	366,69	365,32	-	100	336	38	48	20	9,30
		168-8M-30	6A	168	427,81	426,44	-	100	400	38	48	20	11,40
192-8M-30	6A	192	488,92	487,55	-	100	460	38	48	20	16,00		

KOŁA ZĘBATE METRYCZNE O PODZIAŁCE "M" POD PASY HTD

HTD 8M-50 dla pasa zębatego o szerokości 50 mm

INFORMACJE DODATKOWE	RODZAJ	TYP	RODZAJ TARCZY	IŁOŚĆ ZĘBÓW	Dp	De	Df	Dm	Di	F	L	d	WAGA KG	
STAL	Z TARCZA	22-8M-50	6F	F22	22	56,02	54,65	60	43	-	60	70	12	1,00
		24-8M-50	6F	F25	24	61,12	59,75	66	45	-	60	70	12	1,23
		26-8M-50	6F	F26	26	66,21	64,84	70	48	-	60	70	15	1,50
		28-8M-50	6F	F27	28	71,30	70,08	75	50	-	60	70	15	1,67
		30-8M-50	6F	F29	30	76,39	75,13	83	55	-	60	70	15	1,97
		32-8M-50	6F	F30	32	81,49	80,16	87	60	-	60	70	15	2,27
		34-8M-50	6F	F31	34	86,49	85,22	91	66	-	60	70	15	2,69
		36-8M-50	6F	F33	36	91,67	90,30	97	70	-	60	70	15	2,97
		38-8M-50	6F	F34	38	96,77	95,39	102	75	-	60	70	15	3,23
		40-8M-50	6F	F35	40	101,86	100,49	106	75	-	60	70	18	3,50
		44-8M-50	6F	F38	44	112,05	110,67	120	75	-	60	70	18	3,90
		48-8M-50	6F	F40	48	122,23	120,86	128	80	-	60	70	18	4,30
		56-8M-50	10WF	F48	56	142,60	141,23	150	90	116	60	60	18	5,00
		64-8M-50	10WF	F52	64	162,97	161,60	168	100	137	60	60	18	5,60
		72-8M-50	10WF	F57	72	183,35	181,97	192	100	158	60	60	18	6,80
ŻELIWO	BEZ TARCZY	80-8M-50	10W		80	203,72	202,35	-	110	180	60	60	18	6,90
		90-8M-50	10A		90	229,18	227,81	-	110	204	60	60	18	8,60
		112-8M-50	10A		112	285,21	283,83	-	110	254	60	60	18	9,60
		144-8M-50	10A		144	366,69	365,32	-	110	336	60	60	20	13,80
		168-8M-50	10A		168	427,81	426,44	-	120	400	60	60	20	16,00
		192-8M-50	10A		192	488,92	487,55	-	130	460	60	60	20	22,40

HTD 8M-85 dla pasa zębatego o szerokości 85 mm

INFORMACJE DODATKOWE	RODZAJ	TYP	RODZAJ TARCZY	IŁOŚĆ ZĘBÓW	Dp	De	Df	Dm	Di	F	L	d	WAGA KG	
STAL	Z TARCZA	22-8M-85	6F	F22	22	56,02	54,65	60	43	-	95	105	12	1,55
		24-8M-85	6F	F25	24	61,12	59,75	66	45	-	95	105	12	1,90
		26-8M-85	6F	F26	26	66,21	64,84	70	48	-	95	105	12	2,25
		28-8M-85	6F	F27	28	71,30	70,08	75	50	-	95	105	15	2,55
		30-8M-85	6F	F29	30	76,39	75,13	83	55	-	95	105	15	3,00
		32-8M-85	6F	F30	32	81,49	80,16	87	60	-	95	105	15	3,57
		34-8M-85	6F	F31	34	86,58	85,22	91	66	-	95	105	15	4,00
		36-8M-85	6F	F33	36	91,67	90,30	97	70	-	95	105	15	4,50
		38-8M-85	6F	F34	38	96,77	95,39	102	75	-	95	105	15	5,00
		40-8M-85	6F	F35	40	101,86	100,49	106	75	-	95	105	18	5,20
		44-8M-85	6F	F38	44	112,23	110,67	120	75	-	95	105	18	6,60
		48-8M-85	6F	F40	48	122,23	120,86	128	80	-	95	105	18	7,00
		56-8M-85	6F	F48	56	142,60	141,23	150	90	-	95	105	18	10,0
		64-8M-85	10WF	F52	64	162,97	161,60	168	100	137	95	95	20	10,40
		72-8M-85	10WF	F57	72	183,35	181,97	192	100	158	95	95	20	11,40
ŻELIWO	BEZ TARCZY	80-8M-85	10W		80	203,72	202,35	-	110	180	95	95	20	11,10
		90-8M-85	10A		90	229,18	227,81	-	110	204	95	95	20	12,20
		112-8M-85	10A		112	285,21	283,83	-	110	254	95	95	24	15,00
		144-8M-85	10A		144	366,69	365,32	-	110	336	95	95	24	21,50
		168-8M-85	10A		168	427,81	426,44	-	120	400	95	95	24	24,10
		192-8M-85	10A		192	488,92	487,55	-	130	460	95	95	24	30,60

KOŁA ZĘBATE METRYCZNE O PODZIAŁCE "M" POD PASY HTD

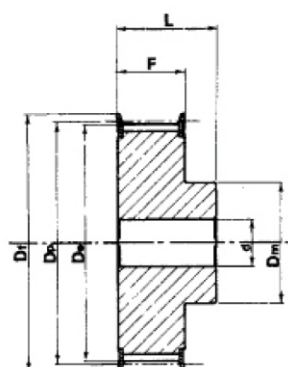

TYP 6F

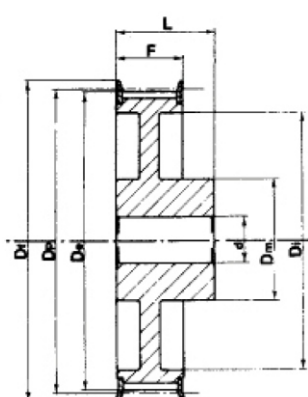

TYP 6WF

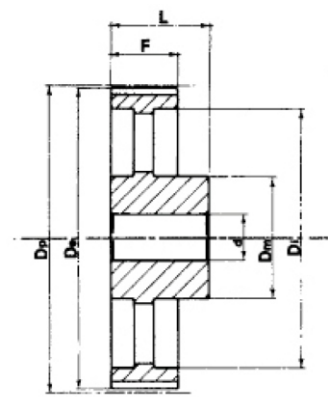

TYP 6A

HTD 14M-40 dla pasa zębatego o szerokości 40 mm

INFORMACJE DODATKOWE		RODZAJ	TYP	ILOŚĆ ZĘBÓW	Dp	De	Df	Dm	Di	F	L	d	WAGA KG
STAL	Z FLANSZĄ	28-14M-40	6F	28	124,78	122,12	128	100	-	54	69	24	4,73
		29-14M-40	6F	29	129,23	126,57	138	100	-	54	69	24	5,09
		30-14M-40	6F	30	133,69	130,99	138	100	-	54	69	24	5,45
		32-14M-40	6F	32	142,60	139,68	154	100	-	54	69	24	6,17
		34-14M-40	6F	34	151,52	148,79	160	100	-	54	69	24	6,88
		36-14M-40	6F	36	160,43	157,68	168	100	-	54	69	24	7,60
		38-14M-40	6F	38	169,34	166,60	184	120	-	54	69	24	8,28
		40-14M-40	6F	40	178,25	175,49	188	120	-	54	69	24	9,26
		44-14M-40	6F	44	196,06	193,28	212	120	-	54	69	24	10,32
		48-14M-40	6WF	48	213,91	211,11	226	135	170	54	69	24	11,50
ŻELIWO	BEZ FLANSZY	56-14M-40	6WF	56	249,55	246,76	256	135	207	54	69	28	13,05
		64-14M-40	6A	64	285,21	282,41	296	135	240	54	69	28	14,40
		72-14M-40	6A	72	320,86	318,06	-	135	278	54	69	28	16,90
		80-14M-40	6A	80	356,51	353,71	-	135	314	54	69	28	18,50
		90-14M-40	6A	90	401,07	398,28	-	135	358	54	69	28	20,00
		112-14M-40	6A	112	499,11	496,32	-	135	456	54	69	28	26,70
		144-14M-40	6A	144	641,71	638,92	-	135	600	54	69	28	35,00
		168-14M-40	6A	168	748,66	745,87	-	135	706	54	69	28	44,20
		192-14M-40	6A	192	855,62	852,82	-	135	813	54	69	28	52,20
		216-14M-40	6A	216	962,57	959,76	-	150	920	54	69	28	62,50

KOŁA ZĘBATE METRYCZNE O PODZIAŁCE "M" POD PASY HTD

HTD 14M-55 dla pasa zębatego o szerokości 55 mm

INFORMACJE DODATKOWE	RODZAJ	TYP	ILOŚĆ ZĘBÓW	Dp	De	Df	Dm	Di	F	L	d	WAGA KG	
STAL	Z FLANSZA	28-14M-55	6F	28	124,78	122,12	128	100	-	70	85	24	5,60
		29-14M-55	6F	29	129,23	126,57	138	100	-	70	85	24	6,10
		30-14M-55	6F	30	133,69	130,99	138	100	-	70	85	24	6,60
		32-14M-55	6F	32	142,60	139,88	154	100	-	70	85	24	7,60
		34-14M-55	6F	34	151,52	148,79	160	100	-	70	85	24	8,60
		36-14M-55	6F	36	160,43	157,68	168	100	-	70	85	24	9,60
		38-14M-55	6F	38	169,34	166,60	184	120	-	70	85	24	10,80
		40-14M-55	6F	40	178,25	175,49	188	120	-	70	85	24	11,20
		44-14M-55	6F	44	196,08	193,28	212	120	-	70	85	24	12,50
		ŻELIWO	BEZ FLANSZY	48-14M-55	10WF	48	213,90	211,11	226	135	170	70	70
56-14M-55	10WF			56	249,55	246,76	256	135	207	70	70	28	14,50
64-14M-55	10WF			64	285,21	282,41	296	135	240	70	70	28	15,60
72-14M-55	10A			72	320,86	218,06	-	135	278	70	70	28	16,90
80-14M-55	10A			80	356,51	353,71	-	135	314	70	70	28	20,00
90-14M-55	10A			90	401,07	398,28	-	135	358	70	70	28	22,60
112-14M-55	10A			112	499,11	496,32	-	135	456	70	70	28	29,50
144-14M-55	10A			144	641,71	638,92	-	135	600	70	70	28	39,00
168-14M-55	10A			168	748,66	745,87	-	135	706	70	70	28	48,50
192-14M-55	10A			192	855,62	852,82	-	135	813	70	70	28	57,80
216-14M-55	10A	216	962,57	959,76	-	135	920	70	70	28	67,00		

HTD 14M-85 dla pasa zębatego o szerokości 85 mm

INFORMACJE DODATKOWE	RODZAJ	TYP	ILOŚĆ ZĘBÓW	Dp	De	Df	Dm	Di	F	L	d	WAGA KG	
STAL	Z FLANSZA	28-14M-85	6F	28	124,78	122,12	128	100	-	102	117	24	7,70
		29-14M-85	6F	29	129,23	126,57	138	100	-	102	117	24	8,40
		30-14M-85	6F	30	133,69	130,99	138	100	-	102	117	24	9,10
		32-14M-85	6F	32	142,60	139,88	154	100	-	102	117	24	10,50
		34-14M-85	6F	34	151,52	148,79	160	100	-	102	117	24	11,90
		36-14M-85	6F	36	160,43	157,68	168	100	-	102	117	32	13,20
		38-14M-85	6F	38	169,34	166,60	184	120	-	102	117	32	15,15
		40-14M-85	6F	40	178,25	175,49	188	135	-	102	117	32	17,10
		44-14M-85	6F	44	196,08	193,28	212	135	-	102	117	32	23,30
		48-14M-85	6F	48	213,90	211,11	226	150	-	102	117	32	25,00
ŻELIWO	BEZ FLANSZY	56-14M-85	10WF	56	249,55	246,76	256	150	207	102	117	32	25,00
		64-14M-85	10WF	64	285,21	282,41	296	150	240	102	102	32	30,50
		72-14M-85	10A	72	320,86	318,06	-	150	278	102	102	32	28,80
		80-14M-85	10A	80	356,51	353,71	-	150	314	102	102	32	30,10
		90-14M-85	10A	90	401,07	398,28	-	150	358	102	102	32	33,00
		112-14M-85	10A	112	499,11	496,32	-	150	456	102	102	32	41,80
		144-14M-85	10A	144	641,71	638,92	-	150	600	102	102	32	52,40
		168-14M-85	10A	168	748,66	745,87	-	150	706	102	102	32	60,30
		192-14M-85	10A	192	855,62	852,82	-	150	813	102	102	32	70,20
		216-14M-85	10A	216	962,57	959,76	-	150	920	102	102	32	81,00

KOŁA ZĘBATE METRYCZNE O PODZIAŁCE "M" POD PASY HTD

HTD 14M-115 dla pasa zębatego o szerokości 115 mm

INFORMACJE DODATKOWE	RODZAJ	TYP	ILOŚĆ ZĘBÓW	Dp	De	Df	Dm	Di	F	L	d	WAGA KG			
STAL	Z FLANSZA	28-14M-115	6F	28	124,78	122,12	128	100	-	133	148	32	9,20		
		29-14M-115	6F	29	129,23	126,57	138	100	-	133	148	32	10,20		
		30-14M-115	6F	30	133,69	130,99	138	100	-	133	148	32	11,20		
		32-14M-115	6F	32	142,60	139,88	154	100	-	133	148	32	13,20		
		34-14M-115	6F	34	151,52	148,79	160	100	-	133	148	32	14,80		
		36-14M-115	6F	36	160,43	157,68	168	100	-	133	148	32	16,60		
		38-14M-115	6F	38	169,34	166,60	184	120	-	133	148	32	19,20		
		40-14M-115	6F	40	178,25	175,49	188	135	-	133	148	32	20,56		
		44-14M-115	6F	44	196,08	193,28	212	140	-	133	148	32	21,93		
		48-14M-115	6F	48	213,90	211,11	226	150	-	133	148	32	25,00		
		56-14M-115	6F	56	249,55	246,76	256	150	-	133	148	32	27,50		
		64-14M-115	10WF	64	285,21	282,41	296	150	240	133	133	32	30,10		
		ŻELIWO	BEZ FLANSZY	72-14M-115	10A	72	320,86	318,06	-	150	278	133	133	32	32,83
				80-14M-115	10A	80	356,51	353,71	-	150	314	133	133	32	35,55
90-14M-115	10A			90	401,07	398,28	-	150	358	133	133	32	41,00		
112-14M-115	10A			112	499,11	496,32	-	150	456	133	133	32	54,40		
144-14M-115	10A			144	641,71	638,92	-	165	600	133	133	32	67,80		
168-14M-115	10A			168	748,66	745,87	-	165	706	133	133	32	75,80		
192-14M-115	10A			192	855,62	852,82	-	165	813	133	133	32	88,30		
216-14M-115	10A			216	962,57	959,76	-	165	920	133	133	32	98,00		

HTD 14M-170 dla pasa zębatego o szerokości 170 mm

INFORMACJE DODATKOWE	RODZAJ	TYP	ILOŚĆ ZĘBÓW	Dp	De	Df	Dm	Di	F	L	d	WAGA KG			
STAL	Z FLANSZA	28-14M-170	6F	28	124,78	122,12	128	100	-	187	202	32	9,20		
		29-14M-170	6F	29	129,23	126,57	138	100	-	187	202	32	10,20		
		30-14M-170	6F	30	133,69	130,99	138	100	-	187	202	32	11,20		
		32-14M-170	6F	32	142,60	139,88	154	100	-	187	202	32	13,20		
		34-14M-170	6F	34	151,52	148,79	160	100	-	187	202	32	14,80		
		36-14M-170	6F	36	160,43	157,68	168	100	-	187	202	32	16,60		
		38-14M-170	6F	38	169,34	166,60	184	120	-	187	202	32	19,20		
		40-14M-170	6F	40	178,25	175,49	188	135	-	187	202	32	20,56		
		44-14M-170	6F	44	196,08	193,28	212	140	-	187	202	32	21,93		
		48-14M-170	6F	48	213,90	211,11	226	150	-	187	202	32	25,00		
		56-14M-170	6F	56	249,55	246,76	256	150	-	187	202	32	27,50		
		64-14M-170	10WF	64	285,21	282,41	296	150	240	187	202	32	30,10		
		ŻELIWO	BEZ FLANSZY	72-14M-170	10A	72	320,86	318,06	-	150	278	187	187	32	32,83
				80-14M-170	10A	80	356,51	353,71	-	150	314	187	187	32	35,55
90-14M-170	10A			90	401,07	398,28	-	150	358	187	187	32	41,00		
112-14M-170	10A			112	499,11	496,32	-	150	456	187	187	32	54,40		
144-14M-170	10A			144	641,71	638,92	-	165	600	187	187	32	67,80		
168-14M-170	10A			168	748,66	745,87	-	165	706	187	187	32	75,80		
192-14M-170	10A			192	855,62	852,82	-	165	813	187	187	32	88,30		
216-14M-170	10A			216	962,57	959,76	-	165	920	187	187	32	98,00		